

Quantification, Characterisation and Evaluation of Mobile IPv6 Handoff Delay

Mai Banh



Why Mobile IP?

- Demand to access Internet technology
- The growth of IP-based data and voice applications in the context of mobile devices (PDAs, laptops and 3rd and 4th generation mobile phones)
- Unified backbone integrated with different access technologies (Bluetooth, GPRS, 802.11 Wireless LANs, ADSL, and DOCSIS cable modems): wired/wireless, narrow/broad-band, public/private networks
- Allow applications on a host to keep on communicating with other hosts while roaming between different IP networks.
- Mobile IP is not simple:
 - Nature of IP with dual tasks: identify hosts and used for routing → static
 - Moving a host's physical attachment point → moving to a new subnetwork with respect to the network's IP topology: new IP address
 - Transparent to higher level protocols
- My study focuses on performance of Mobile IPv6
- IPv6:
 - Improvements over IPv4 (including mobility support)
 - Demand for and relevance of IPv6 markets (North America, Asia, Europe, and Australia)



Talk Outline



- An introduction to IPv6 and IPv4,
- Review of Mobile IPv4
- Comparison Mobile IPv6 to Mobile IPv4,
- Current Mobile IPv6 issues
- Mobile IPv6 handoff techniques and proposals to date
- Link layer technologies
- My experimental characterisation and evaluation of Mobile IPv6 handoff delays
- Conclusions

IPv6 review



- **128 bit addressing**
- **3 types of addresses**
 - Unicast
 - Multicast
 - Anycast
- **3 forms of addresses**
 - Link local address
 - Site local address
 - Global address
- **IPv6 header has a fixed header part of 40 bytes and an extension header part of variable lengths.**

IPv6 addressing –IPv6 header vs. IPv4 header



Ver4	IHL	Type of Service	Total Length		Ver6	Traffic Class	Flow Label		
Identification		Flag	Fragmentation Offset		Payload Length			Next Header	Hop Limit
Time to Live	Protocol	Header Checksum							
Source Address					Source Address				
Destination Address					Destination Address				
Options									

- Suppressed: IHL, Type of Service, Fragmentation fields (Identification, Flag, Fragmentation Offset) and Header Checksum
- Renamed and slightly redefined: Total Length → Payload Length , Protocol Type → Next Header, Time to live (TTL) → Hop Limit
- Two new fields are added: Traffic Class and Flow Label support real-time traffic.
- The option mechanism is entirely revised → Extension Headers (between IPv6 header and transport layer data): Hop-by-hop options header, Routing header, Fragment Header, Authentication Header, Encapsulating Security Payload, Destination Option Header



mbanh@swin.edu.au

http://caia.swin.edu.au

09/03/05

Slide 4

IPv6 vs IPv4



- Sufficient number of IP addresses
- Address Autoconfiguration
- Efficient routing: Routing Header, Destination Option Header
- Mobility through improved routing with route optimisation
- Simplicity
- Extensibility

Quality of Service

- IPv4 QoS relies on IPv4 ToS, the identification of the payload uses a TCP or UDP port. ToS - limited functionality. Payload identification using a TCP or UDP port is not possible when the IPv4 packet payload is encrypted.
- QoS IPv6: Traffic Class (priority) and Flow Label (IPv6 packet flow identification for QoS)

Security

- IPsec: IPv6 includes packet encryption (ESP: Encapsulated Security Payload) and address authentication (AH: Authentication Header)



mbanh@swin.edu.au

http://caia.swin.edu.au

09/03/05

Slide 5

MIPv4 handoff operations

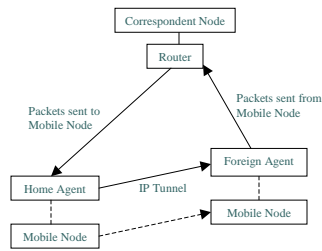

- Mobile Agent Discovery
 - Lifetime of the Agent Advertisement
 - Network prefix of Agent Advertisement
- Registration
- Tunneling
- Binding Update
- Foreign Agent Smooth Handoffs

MIPv4 extensions

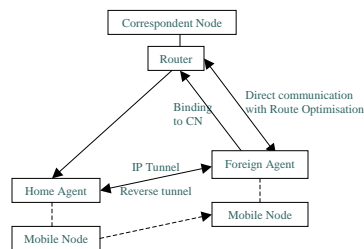

- Reverse Tunneling
- Route Optimisation

MIPv4 issues:

- Private address problems
- Triangle routing
- Handoff problems (jitter, delay, packet losses, excessive amount of signalings)
- Scalability problems
- Security issues
- Hardware compatibility/configuration issues as IPv4 was not built with mobility services in mind

Mobile IPv6 Handoff

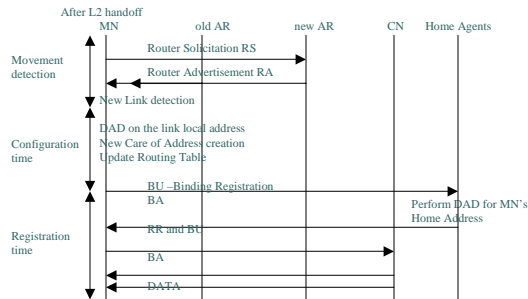

1. Movement Detection
2. Configuration
3. Registration

MIPv6 allows MN to have multiple CoAs and multiple Home Agents



mbanh@swin.edu.au

<http://caia.swin.edu.au>

09/03/05

Slide 8

Mobile IPv6 vs Mobile IPv4



- Larger Address Space
- No Foreign Agent
- Improved Functions
 - No ingress filtering problem of MIPv4
 - Address autoconfiguration
 - Neighbor Discovery: Learning the Access Router's MAC address (ARP process in Mobile IPv4). Assign Link Local, Site Local, Global Address
- Security and Authentication
 - MIPv6 Route Optimisation can operate securely without pre-arranged security associations using MIPv6 Return Routability procedure.
 - IPSec
- Automatic Home Agent Discovery
- Support for Route Optimisation
- Efficient Routing
 - IPv6 Destination Option Header: MN send packets to CNs
 - The IPv6 Routing Header: CN send packets to MN



mbanh@swin.edu.au

<http://caia.swin.edu.au>

09/03/05

Slide 9

Current Mobile IPv6 Issues and IETF Corresponding Approaches



Security

- Extension to Sockets API for MIPv6
- Preconfigured Binding Management Keys for MIPv6
- Mobile IP version 6 Route Optimisation Security Design Background:
- Security Issues in Dynamic Home Agent Address Discovery
- Authentication Protocol for MIPv6
- MIPv6 and Firewalls Problem statement
- MIPv6 Operation with IKEv2 and the revised IPsec Architecture
- MN Identifier Option for MIPv6
- Using IPsec between Mobile and Correspondent IPv6 Nodes

Scalability

- MIPv6 Management Information Base
- Network Mobility (NEMO) (Network Mobility Support Goals and Requirements, Network Mobility Support Terminology, NEMO Home Network models, Analysis of Multihoming in Network Mobility Support, NEMO Management Information Base)

Handoff Problems (Delay, Pack loss, jitter and over air signalings)

- Mobile IPv6 signaling and handoff optimisation (Fast Handovers for Mobile IPv6, Hierarchical Mobile IPv6 mobility management (HMIPv6), Mobile IPv6 Fast Handovers for 802.11 Networks)
- Detecting Network Attachment (Detecting Network Attachment in IPv6 Goals, Link-layer Event Notifications for Detecting Network Attachments)
- QoS for Mobile IPv6

Detecting Network Attachment Issues



- Wireless link properties
 - Unclear boundary
 - Asymmetric reachability
- Inadequacies in RA information: RA messages are not designed to represent link identities and have inherent ambiguities.
 - Link local scope of Router Address
 - Omission of Prefix Information Option
- Delays: DNA delay may result in communication disruption.
 - Delay for receiving a hint
 - Delay for checking current default router unreachability
 - Random delay execution for RS/ RA exchange

Mobile IPv6 Handoff Optimisation Approaches



- MIPv6 Fast Handoff supports
 - Reducing movement detection time
 - Periodic Router Advertisement approach
 - Solicitation on RA Interval Timeout
 - Fast RA
 - Link-up Triggers
 - RA caching in Link-layer Access Points
 - Movement Detection Using Modified ESSIDs
 - Reducing network registration time and minimising signalisation load
 - Fast handoff for MIPv6
 - Hierarchical MIPv6
 - Routing scheme for Macro Mobility Handoff in HMIPv6
 - Access Router based Fast Handover for MIPv6
 - The Cellular Mobile IP6 Using Low Latency Handoff Approach
- MIPv6 Smooth Handoff supports
 - Multiple CoA registrations in MIPv6
 - Simultaneous Bindings
 - Simultaneous Bindings Supported Fast MIPv6
- Other approaches
 - A client based handoff mechanism - Controlling and forcing handoffs



Route Optimisation (RO) hint option

mbanh@swin.edu.au

<http://caia.swin.edu.au>

09/03/05

Slide 12

Link Layer technologies



- Dial up and semi mobile technologies
 - Dial up
 - Semi mobile (DOCSIS/ADSL)
- Wireless link layer technologies
 - GSM Technology
 - GSM
 - GPRS
 - EDGE
 - 3GSM
 - CDMA and its family
 - Bluetooth
 - The 802.11 WLANs



mbanh@swin.edu.au

<http://caia.swin.edu.au>

09/03/05

Slide 13

802.11 Wireless LAN

- Why Wireless LAN
- Link layer handoff

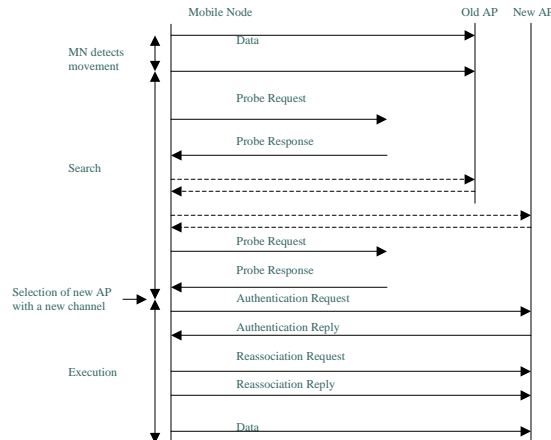

IEEE 802.11b handoff

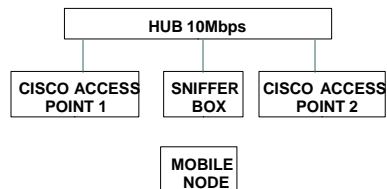

- 2 methods used to trigger handoff
 - Method 1: by varying Access Point power levels
 - Method 2: by alternating Mobile Node's SSID association
- 800 handoff samples each case recorded with MN switching simultaneously between 2 Access Points
 - Method 2 results in a lower mean hand-off value (631ms compared to 864ms)

IEEE 802.11b handoff (cont.)



- Results for method 2 - triggering SSID

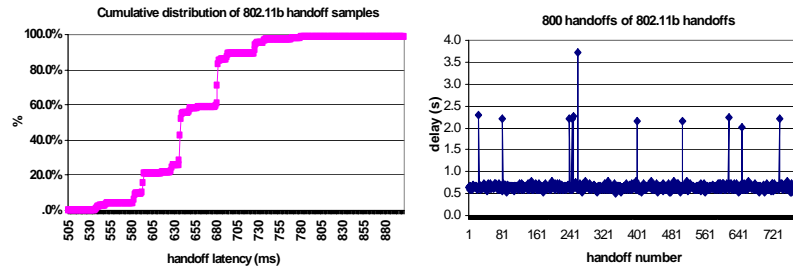

- Results for method 2 – both AP on same or different channels

	Both AP1 and AP2 on Ch. 10	AP1 on Ch. 4 and AP2 on Ch. 10
Mean 802.11b handoff	631ms	667ms
Longest handoff	781ms	825ms
Shortest handoff	506ms	506ms

Evaluation of 802.11b handoff results



- 802.11b handoff deals with all 3 phases - detection, search and execution
- Search phase was the most significant contributor to the handoff latency. The type of wireless card firmware can have a large impact
- Our measured handoff is generally longer than reported in other literature. We measure the entire time it takes for actual Ethernet level bridging to successfully resume after re-association with a new (or previous) AP

MIPv6 Implementation by KAME code



- MN receives new RAs
 - Form new CoAs and start DAD
 - IPv6 address auto-configuration mechanism
- DAD is performed to ensure MN's link local address not duplicated
- Movement detection: NUD mechanism. Can performed simultaneously with DAD
- Select a new CoA and a new default router
- Sending Binding Updates to the Home Agent
- Wait for HA perform DAD
- Receiving Binding Acknowledgements
- Correspondent Registrations

MIPv6 testbed

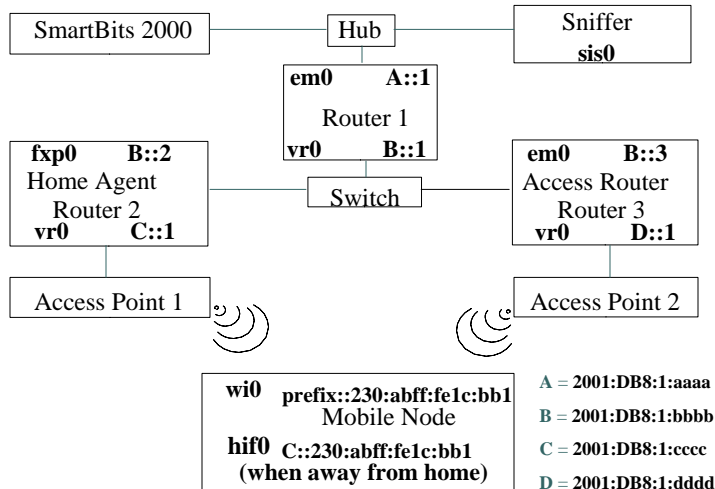

MIPv6 handoff times



- NUD takes 3 seconds (KAME kame-20040628-freebsd49-snap.tgz)

MIPv6 handoff including link layer handoff	Average handoff from home to foreign network (in s)	Average handoff from foreign back to home network (in s)
CN is MIPv6 node (RA interval: 30ms –70ms)	4.770	3.779
CN is non MIPv6 node (RA interval: 30ms –70ms)	4.75	3.638

- Varying Router Advertisement (RA) intervals

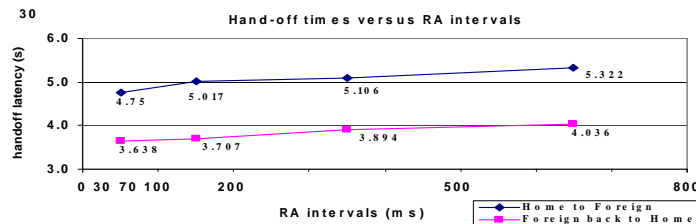

mbanh@swin.edu.au

http://caia.swin.edu.au

09/03/05

Slide 20

Related MIPv6 handoff research



- Cornal et al - MIPL over an 802.11b testbed. RA interval is between 0.5 s and 1.5 s, their measured handoff times are 1.1 s returning to home and 1.8 s moving to foreign
- R.Hsieh et al - simulation setup for an 802.11 network, mean measured basic MIPv6 handoff to foreign network around 5487ms
- N. Montavont et al - reported MIPv6 latency values over an 802.11b network ranging from around 300ms to 1.7s when the RA interval is 50ms. When RA interval is 1500ms MIPv6 handoff latencies are comprised between 1.8s to 3s



mbanh@swin.edu.au

http://caia.swin.edu.au

09/03/05

Slide 21

Evaluation of MIPv6 results



- RFC 3775 - "Due to the temporary packet flow disruption and signaling overhead involved in updating mobility bindings, the Mobile Node should avoid performing an L3 handover until it is strictly necessary". The NUD process helps to determine the need for Mobile Node to acquire a new IP address.
- Specific optimisations are possible, both within each layer (link or network) and between each layer (using link layer state changes to expedite network layer awareness of the need for MIPv6 handoff)

Impact on application performance



- On common webcam application

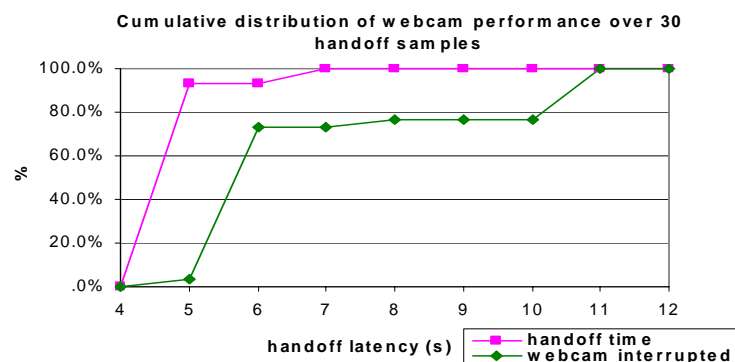

Impact on application performance (cont.)



- On TCP bulk data transfer

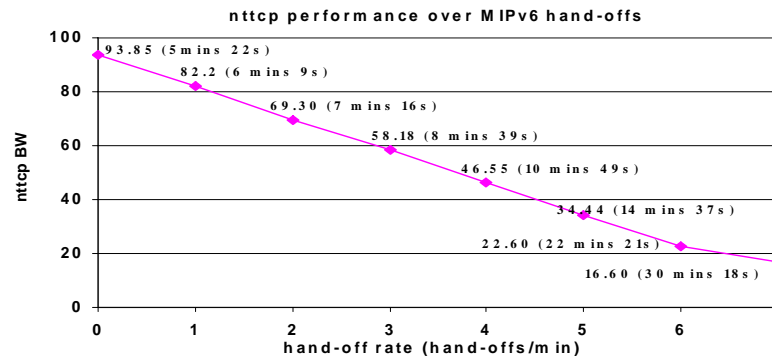

Conclusion



- We experimentally trigger handoff events and measure the time period during which connectivity was lost
- We found that real-world 802.11b handoffs were typically completed in less than 700ms
- The IP level disruption due to 802.11b and MIPv6 handoff together was significantly higher - around 4.8 and 3.8 s
- Tuning the router advertisement (RA) intervals from 30-70ms (the default) to 500-800ms not significantly degrade these handoff times. (short RA intervals may, in practice, not be worth the transmission overhead)
- Default MIPv6 highly disruptive to real-time and interactive applications during handoff events, even if the underlying link layer handoff was instantaneous
- How simple implementation bugs can cause substantial increases in the handoff latencies, regardless of the actual MIPv6 protocol itself